

**iQ parts**  
IQ-PARTS-SHOP.COM



**SPECS &  
INFORMATION**

## Snap Fit Metal Hose Clamp Air Tool Suitable For: Snap Fit Metal Hose Clamps Part No. PHCT-J03-B02-H02



### Description

Pneumatic fitting tool to tighten metallic snap fit hose clamps. Tool comes with TPU protective bumper, 2 power modules and counterbalance hook. Closing force can be set by adjusting the incoming air pressure.

### Outline Dimensions (General Tolerance $\pm 2\text{mm}$ )

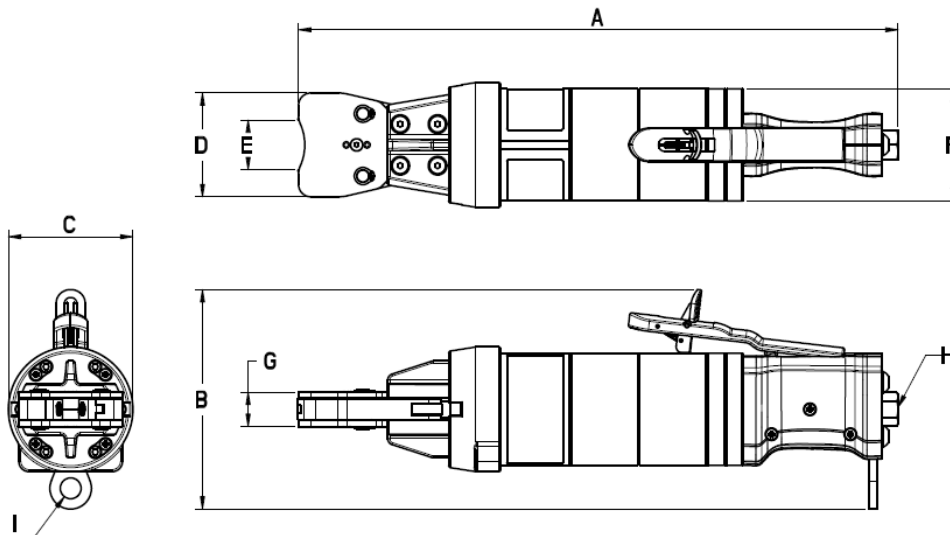

General Properties		
Property	Value	Unit
Hose Clamp Type	Metal Ear Clamp	-
Weight	0.91 (2.01) $\pm 2\%$	kg (lb)
(A) Length	289 (11.38)	mm (inch)
(B) Height	106 (4.17)	mm (inch)
(C) Width	60 (2.36)	mm (inch)

General Properties Continued		
Property	Value	Unit
(D) Jaw Width	50 (1.97)	mm (inch)
(E) Jaw Closing Range	0 (0.0) to 24 (0.94)	mm (inch)
(F) Body Diameter	54 (2.13)	mm (inch)
(G) Jaw Height	17 (0.67)	mm (inch)
(H) Air Inlet Thread Size	1/8"	Inch BSP
(I) Lanyard Hole Diameter	10 (0.39)	mm (inch)



## Mechanical

Jaw Closing Force			
Pressure <sup>1</sup> Bar (psi)	Max Force <sup>2</sup>		
	N	Kgf	Lbf
2 (29.0)	307	31	69
3 (43.5)	507	51	114
4 (58.0)	714	72	160
5 (72.5)	933	95	209
6 (87.0)	1149	117	258

<sup>1</sup> The closure force is dependent on suitable compressed air supply flow rate >50L/min

<sup>2</sup> Force measured using a 50KN calibrated Zwick Tensometer



Further Operating Details, including tool setup, and maintenance can be found in the original Instructions supplied with the tool. Please refer to HCL for spare parts and repair.

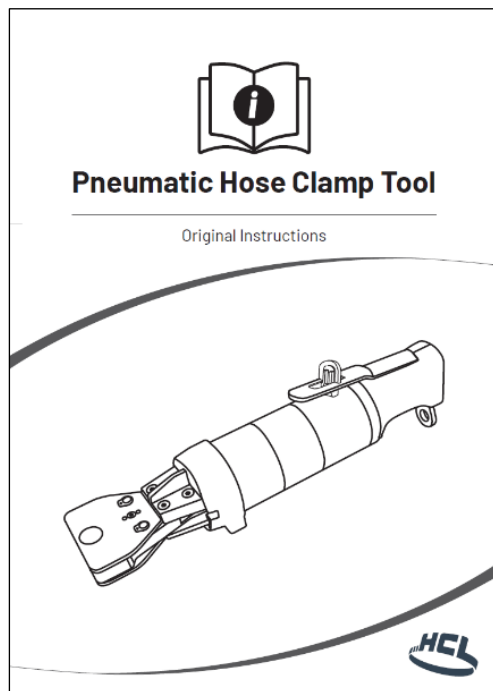





## Important Notice to User

**Storage:** Tool should be installed and used in a dry environment. When not in use store in a cool dry area in original carton.



Original Tool Carton with generic tool example shown

**Warranty:** HCL warrants that all products when stored, used and maintained in accordance with HCL's written instructions will meet or exceed the above specification. HCL makes no other warranties or conditions, expressed or implied, including, but not limited to, any implied warranty or condition of merchantability or fitness for a particular purpose or any implied warranty or condition arising out of a course of dealing, custom or usage of trade. If any HCL product does not conform to this warranty, then only replacement or refund of the affected parts will be considered.

**Limitation of Liability:** Except where expressly prohibited by law, HCL will not be liable for any damage or loss arising from the use of the HCL product.

**Product Use:** It is the user's responsibility to determine the suitability of the product for the task it is to be used for. HCL reserve the right to continually improve its product and would advise the user to contact HCL at all times to ensure they have up to date current data to work with.



info@iq-parts.nl  
Harsweg 34A  
2461 EZ Ter Aar  
T +31 252 624 126  
The Netherlands